

INSTALLATION MANUAL FOR ROOM AIR CONDITIONER

(Split Wall Mounting Type)

- For correct installation, read this manual before starting installation. Please save this manual in a safe place.
- Only trained and qualified service personnel should install, repair or service air conditioning equipment. Users should not install the air conditioner by themselves.
- Pictures in this manual may be slightly different from the air conditioner you purchased. These pictures are only sketches.

INSTALLATION PRECAUTION

Installation in the following places may cause trouble. If it is unavoidable to use in such places, please consult with the dealer:

- A place full of machine oil.
- A saline place such as coast.
- A place full of sulfide gas such as hot-spring resort.
- Places where there are high frequency machines such as wireless installation, welding machine, and medical facility.
- A place of special environmental conditions.

Indoor Unit

- A place where is no obstacle near the inlet and outlet area.
- A place which can bear the weight of the indoor unit.
- A place which provides the spaces around the indoor unit as required right in the diagram.
- A place 1m or more from TV, radio instrument, in the center of the room is perfect.
- A place which is far from heat, steam and inflammable gas.
- Install the indoor unit on the wall where the height from the floors more than 2.3 meters.

Outdoor Unit

- A place, which is convenient to installation and not exposed to a strong wind.
- A place can bear the weight of the outdoor unit and where the outdoor unit can be held in the horizontal position.
- A place where the operation noise and discharge air do not disturb you neighbor.
- A place free of a leakage of combustible gases.
- An allowable head level at the connective piping is less than 5m and length of the connective piping is up less than 10m.
- A place, which provides the spaces around the outdoor unit as required right in the diagram.
- Unavailable to children.

NOTE:

1. The appliance shall not be installed in the laundry. All the connection must be in accordance with national regulations.
2. For detailed installation acceptance, please refer to your contract with the power supplier if restrictions do apply for products like washing machines, air conditioners or electrical ovens.
3. For power details of the air conditioner, refer to the rating plate of the product. Contact your local dealer if you have any questions.

Installation Parts

Part No.	Name of part	Q'ty
1	Installation plate	1
2	Clip anchor	8
3	Mounting screw A ST3.9x25-C-H	8
4	Remote controller	1
5	Remote controller holder	1
6	Mounting screw B ST2.9x10-C-H	2
7	Refrigerant pipe	Liquid side φ 6.35 (<24000Btu/h)
		φ 9.53 (≥24000Btu/h)
		Gas side φ 12.7 (<24000Btu/h)
	φ 16 (≥24000Btu/h)	
8	Seal	
9	Drain elbow	

Cautions on remote controller installation

- Before installation, operate the remote controller to determine its location in a reception range.
- Keep the remote controller at least 1m apart from the nearest TV set or stereo equipment.
- Do not install the remote controller in a place exposed to direct sunlight or close to a heating source, such as a stove.
- Note that the positive and negative poles are right positions when loading batteries.

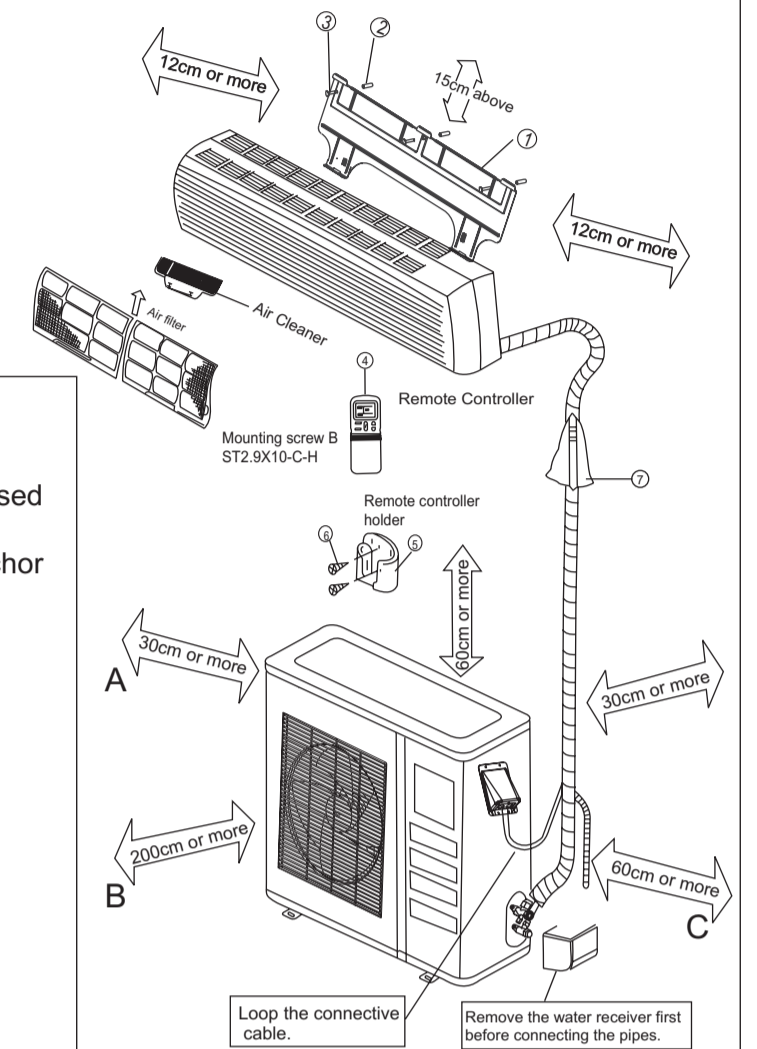

Caution

- The outdoor unit should not be exposed to strong wind.
- Fix the outdoor unit with φ 10 anchor bolts.

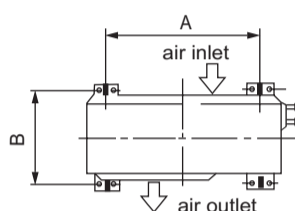

Model	A	B
<24000Btu/h	560	335
≥24000Btu/h	590	333

- If need suspending installation, consults the corresponding requirement.

NOTICE: There should be at least two of the A, B, C direction are free from blocking.

1 INDOOR UNIT INSTALLATION

1. Cutting A Hole and Mounting Installation Plate

Installation Plate and Its Measures (Unit: mm)

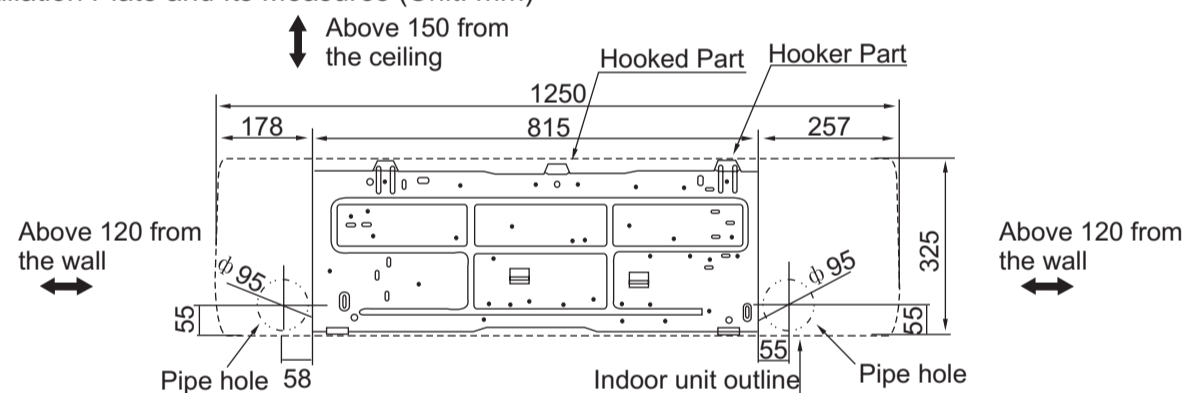

1. Fix the installation plate.

1. Install the installation plate horizontally on structural members in the wall with the spaces provided around the plate.
2. In case of block, brick, concrete or similar type walls, make 5mm dia. holes in the wall. Insert clip anchors for appropriate mounting screws.
3. Fix the installation plate on the wall.

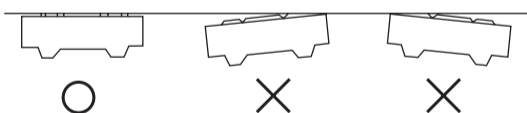

2. Cutting a hole.

1. Determine the pipe hole position using the installation plate, and drill the pipe hole (φ 95mm) so it slants slightly downward.
2. Always use a piping hole cap when piercing a wall, wire lath or metal plate.

2. Connective Pipe and Drainage Installation

1. Drainage

1. Run the drain hose sloping downward. Do not install the drain hose as illustrated below.

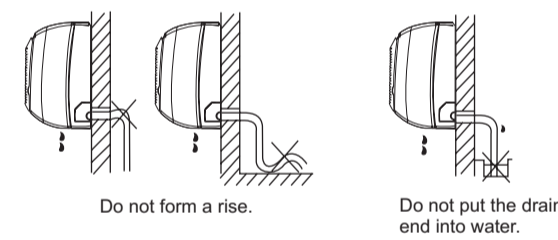

2. When connecting extension drain hose, insulate the connecting part of extension drain hose with a shield pipe.

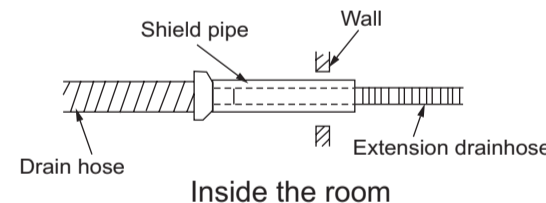

2. Connective pipe

1. For the left-hand and rear-left-hand piping, install the piping as shown. Bend the connective pipe to be laid at 43mm height or less from the wall.

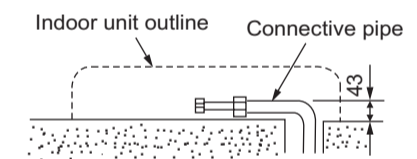

2. Fix the end of the connective pipe.

Caution

- Connect the indoor unit first then the outdoor unit.
- Bend and arrange the pipe carefully.
- Insulate both of the auxiliary piping.
- Drainage can not annoy your neighbor.

3. Indoor unit Installation

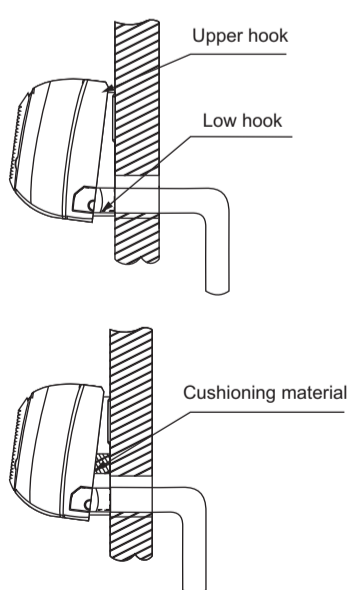

1. Pass the piping through the hole in the wall.
2. Put the upper claw at the back of the indoor unit on the upper hook of the installation plate. Move the indoor unit from side to side to see that it is securely hooked.
3. Push the lower part of the indoor unit up on the wall.
4. Piping can easily be made by lifting the indoor unit with a cushioning material at the remote controller holder side between the indoor unit and the wall.

4. Electrical Work

Prepare the power source for exclusive with the air conditioner. The supply voltage must be the same as the rated voltage of the air conditioner.

Model	Power Supply	Input Rated Amp (Switch/Fuse)	AWG(MIN.)	
			Power Supply cord	Connecting cable
< 24000Btu/h	220-230V~ 60Hz or	32/20A	12	18
≥ 24000Btu/h	220-240V~ 50Hz	32/25A		

NOTE: A disconnection device having an air gap contact separation at least 3mm in all conductors should be incorporated in the fixed wiring according to the National Wiring Regulation.

Caution

- Perform the wiring with sufficient capacity.
- Installation places legally require a short circuit isolator to be attached to prevent electrical shock.
- Do not extend the power cable code by cutting.
- The plug of the air conditioner takes a grounding leg, so clients should use a grounding socket so that the air conditioner can be grounded efficiently.

5. Connecting Cables

1. Lift the panel, loose the screw then open the Electric Box Cover.
2. Connect the wires to the terminals on the control board individually according to the outdoor unit connection.
3. Wrap those cables not connected with terminals with insulation tapes, so that they will not touch any electrical components.

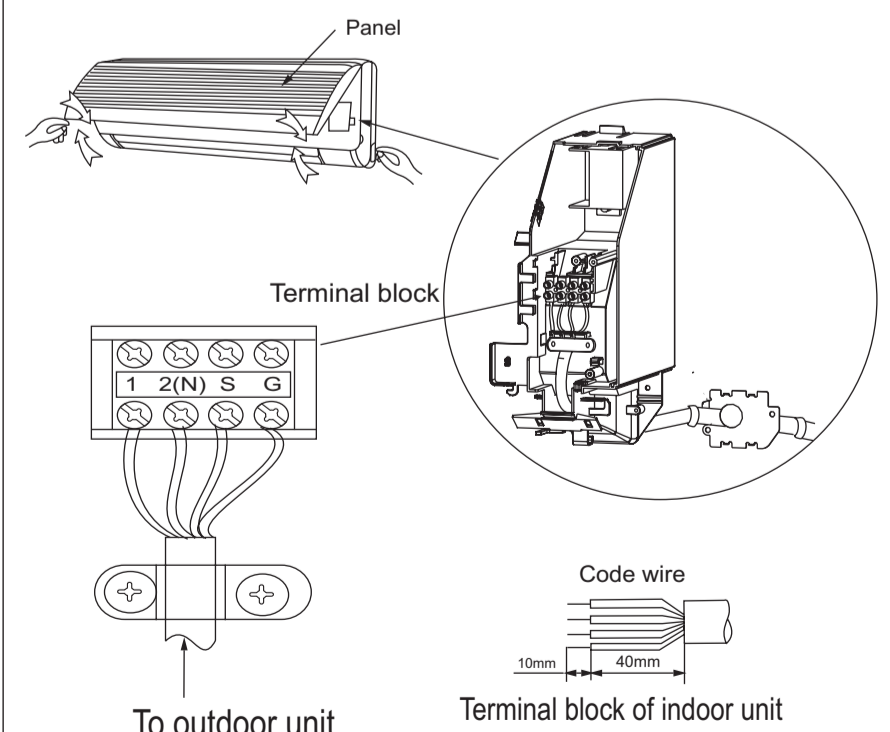

1 INDOOR UNIT INSTALLATION

6. Piping and Bandaging

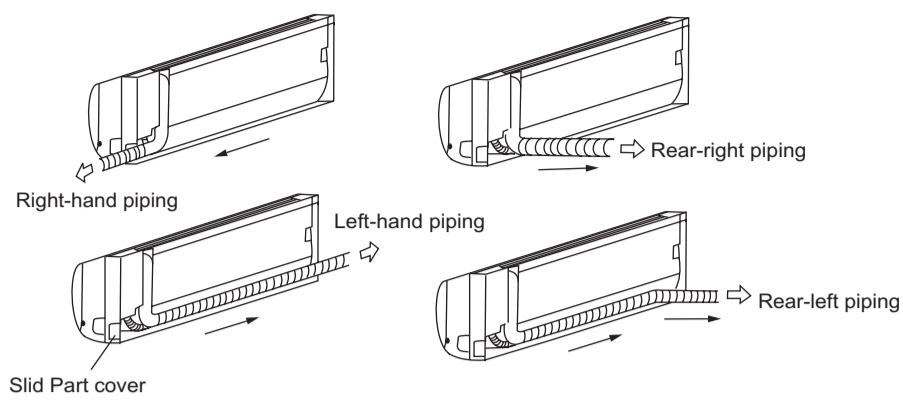

- For the left-hand and right-hand piping, remove the rear plate bushing from the left side of the rear plate.
- Explain to clients that the rear plate bushing must be kept as it may be used when relocate the air conditioner to any other place.
- Wind the connective cable, drain hose and wiring with tape securely, evenly.

Caution

- Install the drain hose at the bottom of the connective cable.
- Reasonably and carefully arrange and bandage the piping in case to damage the drain hose and connective piping.

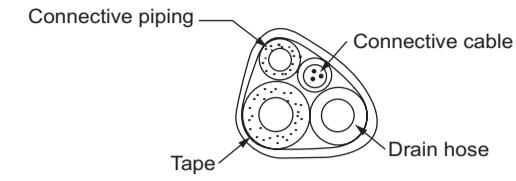

- Make sure to run the drain hose sloped downward to drain out the condensation smoothly.
- Never intercross nor inter twist power line with any other wiring.

2 OUTDOOR UNIT INSTALLATION

1. Outdoor Installation Precaution

- Install the outdoor unit on a rigid base to prevent increasing noise level and vibration.
- Determine the air outlet direction where the discharged air is not blocked.
- In the case that the installation place is exposed to strong wind such as a seaside or high position, secure the normal fan operation by putting the unit lengthwise along the wall or using a dust or shield plates.
- Specially in windy area, install the unit to prevent the admission of wind.
- If need suspending installation, the installation wall should be solid brick, concrete or the same intensity construction, or actions to reinforce, damping, supporting should be taken. The connection between bracket and wall, bracket and the air conditioner should be firm, stable and reliable.
- If need suspending installation, the installation bracket should accord with technique requirement in the installation bracket diagram.

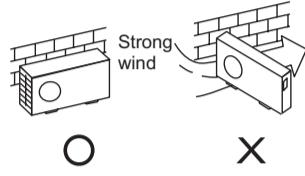

2. Drain Elbow Installation

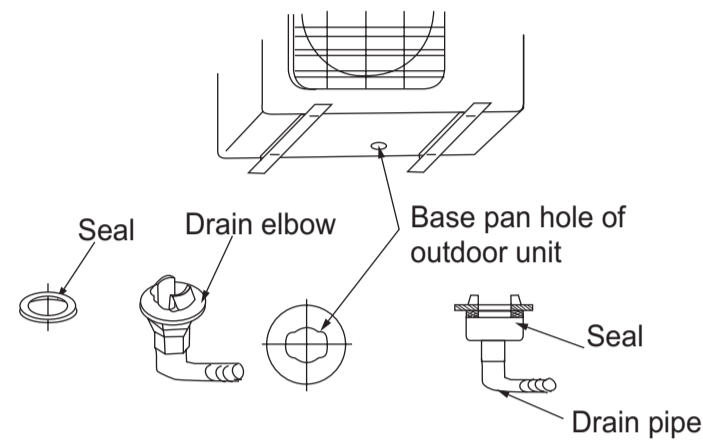

Fit the seal into the drain elbow, then insert the drain elbow into the base pan hole of outdoor unit, rotate 90° to securely assemble them. Connecting the drain elbow with an extension drain hose (Locally purchased), in case of the water draining off the outdoor unit during the heating mode

3. Refrigerant Piping Connection

1. Flaring

- Cut a pipe with a pipe cutter.
- Insert a flare nut into a pipe and flare the pipe.

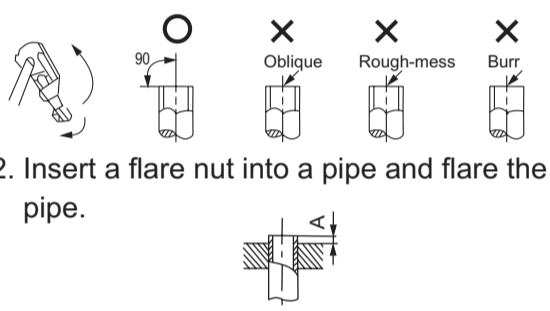

Outlet diam. (mm)	A (mm)	
	Max.	Min.
φ 6.35	1.3	0.7
φ 9.53	2	1.8
φ 12.7	1.8	1.0
φ 16	2.4	2.2

2. Tightening Connection

- Align pipes to be connected.
- Sufficiently tighten the flare nut with fingers, and then tighten it with a spanner and torque wrench as shown.

Caution

- Excessive torque can break nut depending on installation conditions.

Outlet diam.	Tightening torque	Additional tightening torque
φ 6.35mm	1570(N.cm) (160kgf.cm)	1960(N.cm) (200kgf.cm)
φ 9.53mm	3040(N.cm) (310kgf.cm)	3430(N.cm) (350kgf.cm)
φ 12.7mm	4900(N.cm) (500kgf.cm)	5390(N.cm) (550kgf.cm)
φ 16mm	7360(N.cm) (750kgf.cm)	7850(N.cm) (800kgf.cm)

4. Wiring Connection

- Remove the cover control from the unit by loosening the 3 screws.
- Dismount caps on the conduit panel.
- Temporarily mount the conduit tubes (not included) on the conduit panel.
- Properly connect both the power supply and low voltage lines to the corresponding terminals on the terminal block.
- Ground the unit in accordance with local codes.
- Be sure to size each wire allowing several inches longer than the required length for wiring.
- Use lock nuts to secure the conduit tubes.

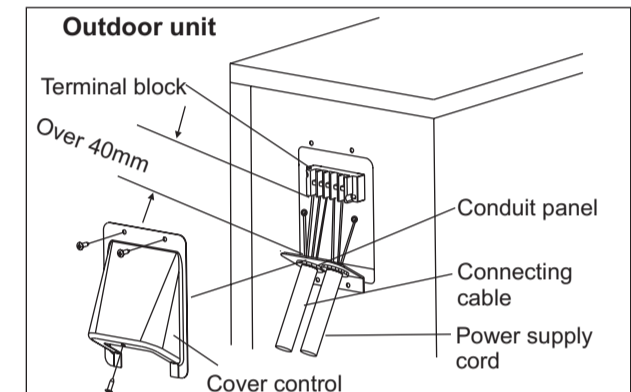

WARNING

- Be sure to comply with local codes while running the wire from the indoor unit to the outdoor unit.
- Every wire must be connected firmly.
- No wire should be allowed to touch refrigerant tubing, the compressor or any moving parts.
- Loose wiring may cause the terminal to overheat or result in unit malfunction. A fire hazard may also exit. Therefore, be sure all wiring is tightly connected.

Note : To prevent wires loosening or leaving the Cord Clamp, please select proper cord diameter to fill the holes on the cord clamp.

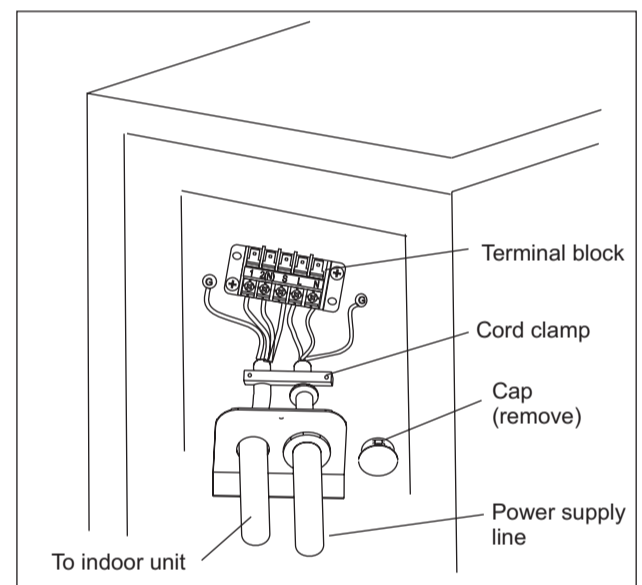

3 AIR PURGE AND TEST OPERATION

1. Air Purge

Choose purge method from the table:

Connective pipe length	Air purging method	Additional amount of refrigerant to be charged
Less than 5m	Use vacuum pump	-----
5 ~ 10m	Use vacuum pump	(L-5)X30g

- When relocate the unit to an other place, perform evacuation. using vacuum pump .
- For the R407C/R410A refrigerant models, make sure the refrigerant added into the air conditioner is liquid form in any case.

Caution in Handling the Packed Valve

- Open the valve stem until it hits against the stopper. Do not try to open it further.
- Securely tighten the valve stem cap with a spanner or the link.
- Valve stem cap tightening torque. (See Tightening torque table above)

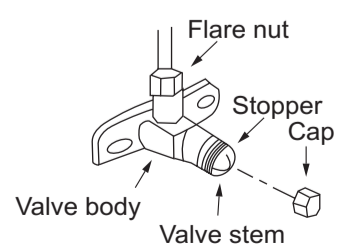
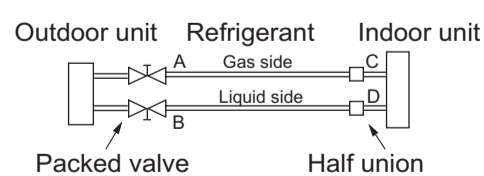

Using the Vacuum Pump

(For method of using a manifold valve, refer to its operation manual)

- Completely tighten the flare nuts A, B, C, D, connect the manifold valve charge hose to a charge port of the packed valve on the gas pipe side.
- Connect the charge hose connection to the vacuum pump.
- Fully open the handle Lo of the manifold valve.
- Operate the vacuum pump to evacuate. After starting evacuation, slightly loose the flare nut of the packed valve on the gas pipe side and check that the air is entering. (Operation noise of the vacuum pump changes and a compound meter indicates 0 instead of minus)
- After the evacuation is complete, fully close the handle Lo of the manifold valve and stop the operation of the vacuum pump.
- Make evacuation for 15 minutes and more and check that the compound meter indicates -76cmHg.
- Turn the stem of the packed valve B about 45° counterclockwise, securely tighten the flare nut after 6-7 seconds. Disconnect the charge hose from the charge connection of the packed valve at the gas pipe side.
- Fully open the packed valves B and A.
- Securely tighten the cap of the packed valve.

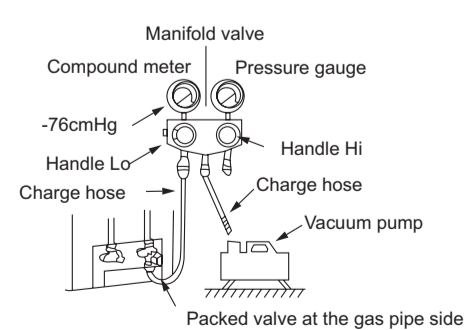

2. Gas Leak Check

Make sure no gas from connections with leak detector or soap water.

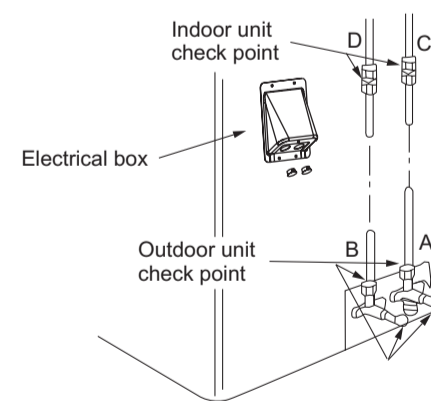

Caution

A: Lo packed valve B: Hi packed valve C and D are ends of indoor unit connection.

3. Test Operation

Perform test operation after completing gas leak check at the flare nut connections and electrical safety check.

- Connect the power, push the ON/OFF button on the remote controller to begin testing.
- Push mode button, select cooling, heating, fan mode to check if all the functions works well.
- When the ambient temperature is too low (lower than 17 °C), the unit cannot be controlled by the remote controller to run at cooling mode. At this time, manual operation can be taken.
 - Open the front panel of the indoor unit;
 - Connect the power, the air conditioner begin to operate, check if there is any abnormal.
 - A protection feature prevents the air conditioner from being activated for about 3 minutes when it is restarted immediately after operation or when the power switch is turned on.
- Be sure to set the manual switch on OFF after finishing the test operation. Then installer should explain how to manipulate, fix, and maintain their air conditioner. Also tell them that regular check of the installation bracket and maintenance are necessary. Clients should apply for inspecting to relevant department so as to ensure the air conditioner can operate normally, safely and reliably.

